

NDA-3083-PIP Pendant interface plate FD 3100i

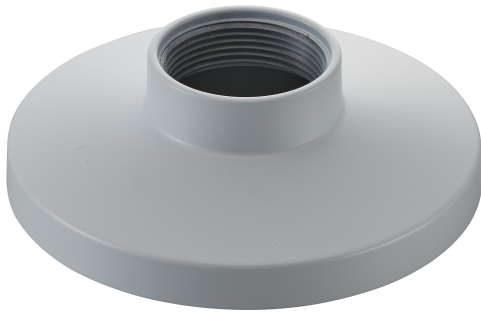

- ▶ Pendant interface plate for FLEXIDOME indoor 3100i, FLEXIDOME indoor 3100i IR and FLEXIDOME outdoor 3100i IR
- ▶ Modular design for fast and easy installation
- ▶ Weather resistant finish to maintain cosmetic appearance

This pendant interface plate is designed to enable easy installation of the FLEXIDOME 3100i cameras to Bosch modular pendant mounts or any third party mount with 1.5 inch NPT threads.

The accessories are easy to install and can be combined to simplify installation in multiple locations while retaining the same look and feel.

Functions

The NDA-3083-PIP is especially designed for the FLEXIDOME 3100i family cameras. It provides a safe and robust solution to mount the camera to:

- NDA-U-WMT Pendant wall mount
- NDA-U-PMT Pendant pipe mount

Regulatory information

Environmental

Salt mist	IEC60068-2-52
Vibration	IEC60068-2-6
Shock	IEC60068-2-27
Impact	IK10

Installation/configuration notes

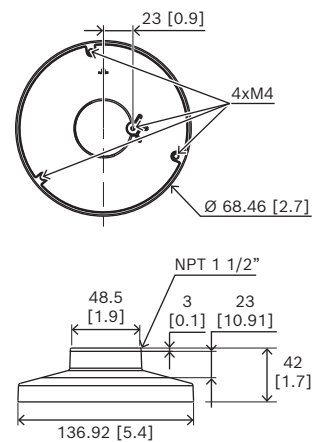

Dimensions in mm (inch)

Parts included

Quantity	Component
1	NDA-3083-PIP Pendant interface plate
4	M4 x 12 screws
1	Quick installation guide

Technical specifications

Mechanical

Color (RAL)	RAL 9003 Signal white
-------------	-----------------------

Material	Aluminum
Thread type	NPT1.5
Dimensions (Ø x H) (mm)	137 mm x 42 mm
Dimensions (Ø x H) (in)	5.39 in x 1.65 in
Weight (g)	183 g
Weight (lb)	0.40 lb

Ordering information

NDA-3083-PIP Pendant interface plate FD 3100i

Pendant interface plate for FLEXIDOME indoor 3100i, FLEXIDOME indoor 3100i IR and FLEXIDOME outdoor 3100i IR cameras

Order number **NDA-3083-PIP**

Represented by:

Europe, Middle East, Africa:
Bosch Security Systems B.V.
P.O. Box 80002
5600 JB Eindhoven, The Netherlands

Germany:
Bosch Sicherheitssysteme GmbH
Robert-Bosch-Platz 1
D-70839 Gerlingen

North America:
Bosch Security Systems, LLC
130 Perinton Parkway
Fairport, New York, 14450, USA

Asia-Pacific:
Robert Bosch (SEA) Pte Ltd, Security Systems
11 Bishan Street 21
Singapore 573943